

D-Sub – Housing range for subminiature D connectors

Page

General information – hoods for screw locking **07.02**

Thermoplastic top and side entry hoods with knurled screws **07.04**

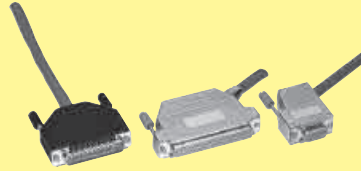

Thermoplastic side entry hoods with knurled screws **07.05**



Thermoplastic top entry hoods with knurled or locking screws **07.06**



Full metal top and side entry hoods with knurled screws **07.07**

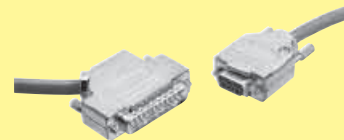

Full metal top and side entry hoods with short screws ... **07.08**



Full metal top and side entry hoods with different screw options **07.09**

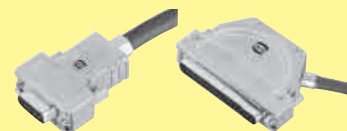

General information – hoods for spring or slide locking **07.10**

Thermoplastic top and side entry hoods for spring or slide locking **07.11**



Full metal top and side entry hoods for spring or slide locking **07.12**

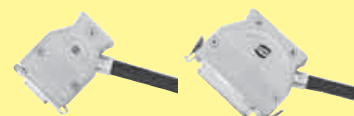

HARTING – Guarantee a secure connection

Modern electronic applications demand a high degree of mechanical and electrical security.

To meet these requirements, continuous screening from the cable to the PCB via the connector is achieved by using state of the art components to DIN 41 652.

HARTING offer many solutions. These utilise various combinations of male and female connectors with hoods, featuring either screw locking or latching facilities.

Only 2 examples are shown:

- Continuous security screening and grounding with screw locking and metallized hood.
- Continuous grounding and vibration proof latching system with metallized hood.

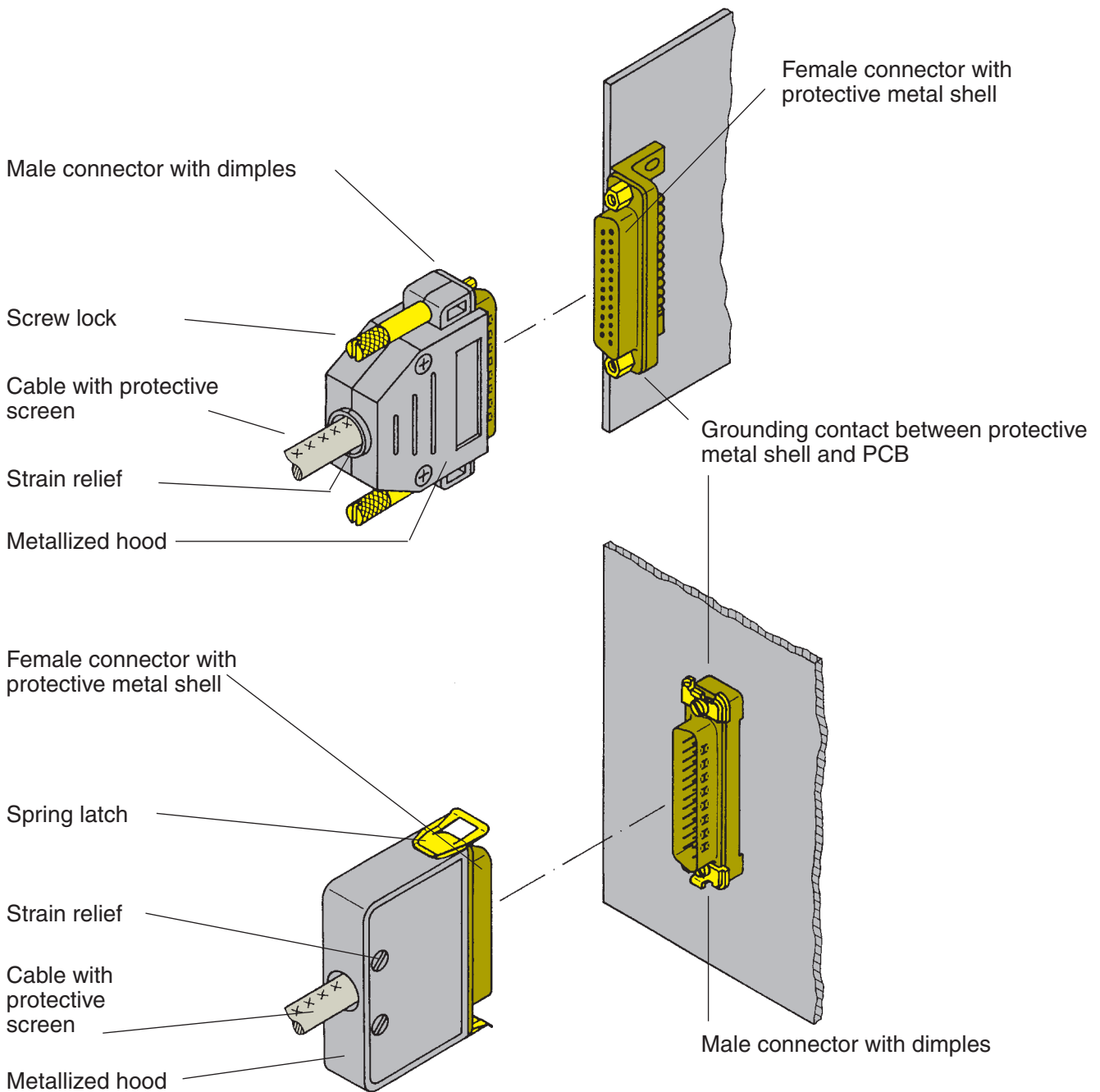

D-Sub - H

Connector hoods for screw locking

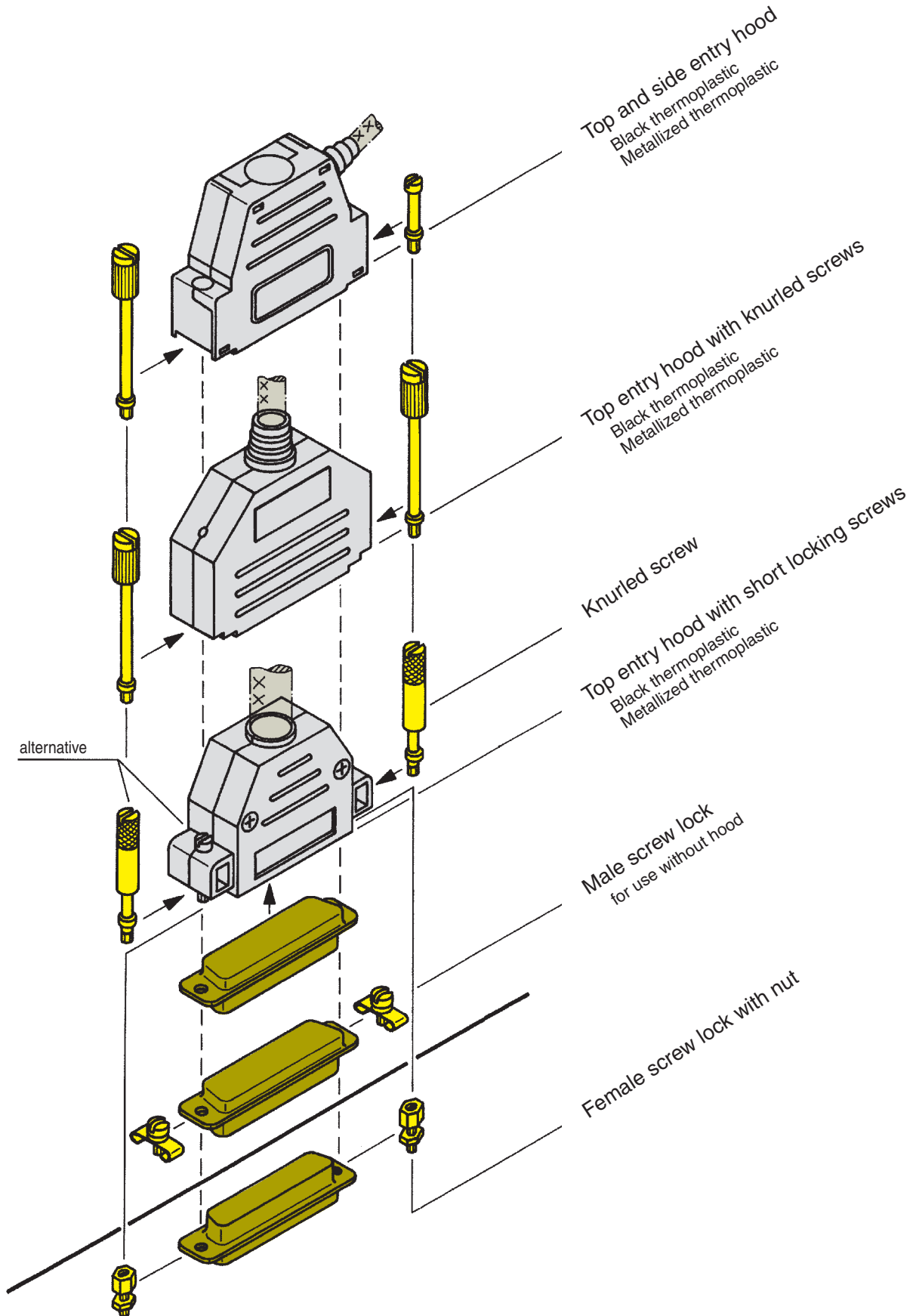

D-Sub - H

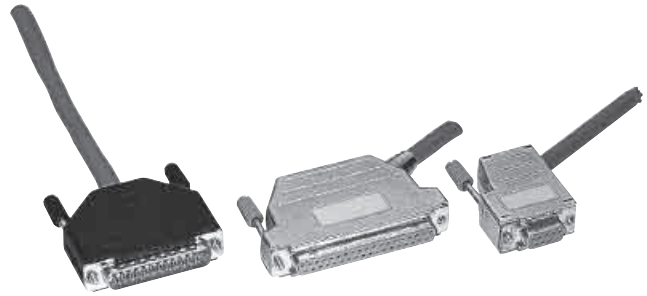

Top and side entry hoods with knurled screws

Identification No. of contacts Part No. Drawing Dimensions in mm

Top entry hood
Black thermoplastic

9	09 67 009 0424
15	09 67 015 0424
25	09 67 025 0424
37	09 67 037 0424
50	09 67 050 0424

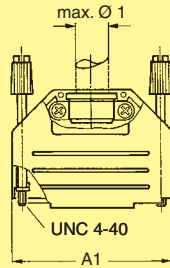

	A1	A2	B	C1	C2	max. Ø 1	max. Ø 2
9	31.5	32.5	15	34	38	8.0	11.5
15	40.0	41.0	15	34	38	11.5	11.5
25	53.5	54.5	15	40	40	11.5	11.5
37	71.0	71.0	15	40	40	11.5	11.5
50	67.5		19	40		14.0	

C1: non-metallized

C2: metallized

Top entry hood
Metallized thermoplastic

9	09 67 009 0425
15	09 67 015 0425
25	09 67 025 0425
37	09 67 037 0425

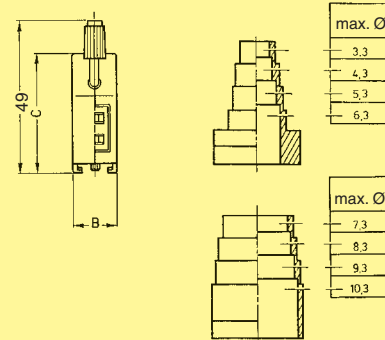
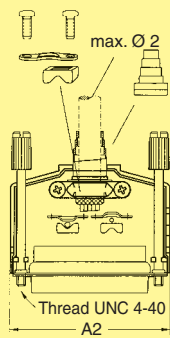

Cut appropriate cable entry to fit actual cable diameter

Top and side entry hood
Black thermoplastic

9	09 67 009 0434
15	09 67 015 0434
25	09 67 025 0434
37	09 67 037 0434 ¹⁾

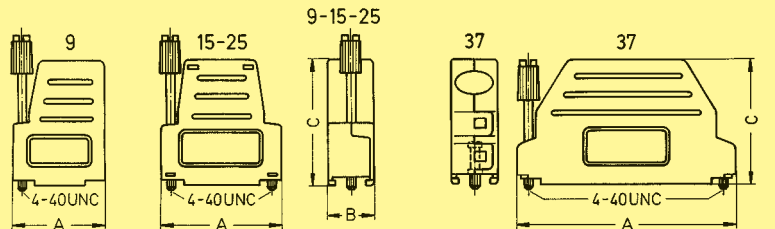

	A	B	C
9	31.5	15	40.0
15	40.0	15	40.0
25	53.5	15	43.0
37	71.3	15	42.5

Top and side entry hood
Metallized thermoplastic

9	09 67 009 0435
15	09 67 015 0435 ²⁾
25	09 67 025 0435 ²⁾
37	09 67 037 0435 ¹⁾

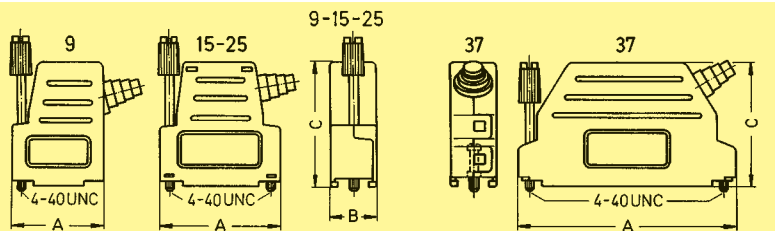

Grommet
for top and side entry
black thermoplastic
hood

09 67 001 9988



¹⁾ 37 ways is only side entry

²⁾ Cable clamp kit for two outputs is available with Part No. 09 67 001 9988 (it includes: screw, metal clamp, plastic insert and grommet)

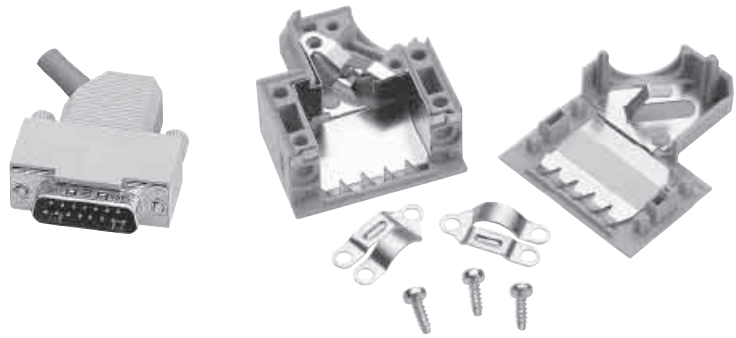

Side entry hoods with knurled screws

Identification No. of contacts Part No. Drawing Dimensions in mm

Hood¹⁾
grey thermoplastic
RAL 7032

9	09 67 009 0571
15	09 67 015 0571
25	09 67 025 0571
37	09 67 037 0571
50	09 67 050 0571

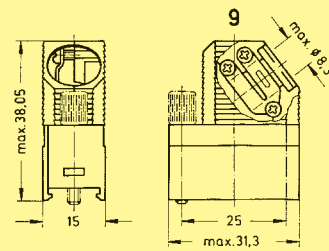

grey thermoplastic
with internal
tin-plate screening

9	09 67 009 0573
15	09 67 015 0573
25	09 67 025 0573
37	09 67 037 0573
50	09 67 050 0573

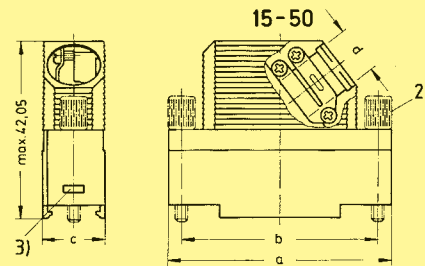

9-37 way
for packaging density
of 3 TE (15.24 mm)

	a max.	b	c	d max.
15	39.62	33.3	15	Ø 9.1
25	53.52	47.0	15	Ø 11.5
37	69.80	63.5	15	Ø 12.8
50	67.41	61.1	19	Ø 14.5

Knurled screw

Thread UNC
Thread M3

9-50

09 67 000 9971⁴⁾
09 67 001 9965*

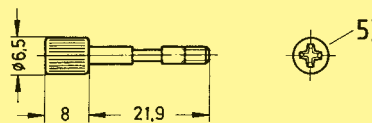

Grey head / Nickel plated steel

Thread UNC
Thread M3

9-50

09 67 001 9978
09 67 001 9977

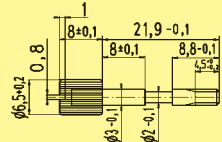

Full metal part

Tooling⁶⁾

for assembly
of hoods

Top part
Bottom part

09 99 000 0215*
09 99 000 0216*

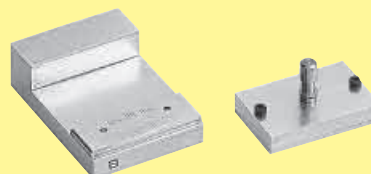

* Not normally kept in stock

¹⁾ Order knurled screw separately

²⁾ Before assembling the hood, the knurled screws must be inserted into the lower hood part.

³⁾ For retained nut when using slide lock or female screw lock

⁴⁾ 9 way 1 per hood – 15-50 way 2 per hood

⁵⁾ Screw driver type ISO PH 1 for philips screw No 1 ISO norm 4757

⁶⁾ Additional tooling (bench press) see chapter 32

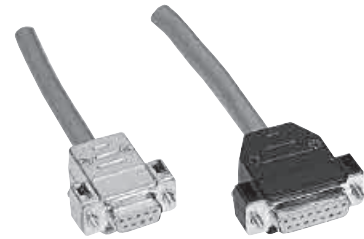

Top entry hoods with knurled or locking screws

Identification No. of contacts Part No. Drawing Dimensions in mm

Hood
Black thermoplastic with short locking screws

9	09 67 009 0442
15	09 67 015 0442
25	09 67 025 0442
37	09 67 037 0442
50	09 67 050 0442

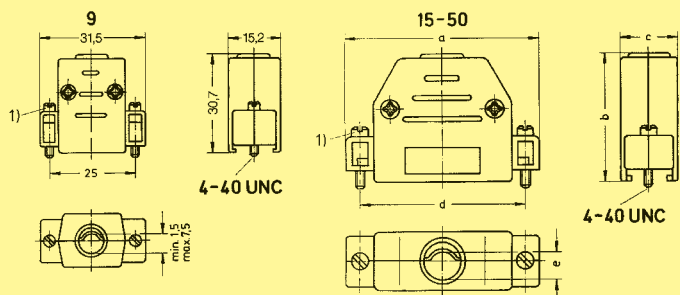

Hood
Metallized thermoplastic with short locking screws

9	09 67 009 0443
15	09 67 015 0443
25	09 67 025 0443
37	09 67 037 0443
50	09 67 050 0443

	a	b	c	d	e	
					min.	max.
15	40.0	34.7	15.2	33.3	3.3	8.5
25	53.2	39.7	15.2	47.0	3.5	11.0
37	70.0	39.7	15.2	63.5	3.5	11.0
50	67.5	39.7	18.2	61.1	9.3	12.0

Knurled screw
for metallized hood
Thread UNC
Thread M3

9-50	09 67 000 9925 ²⁾
9-50	09 67 000 9930 ²⁾

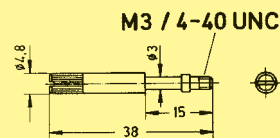

¹⁾ Use of knurled screws is possible. Please order separately
²⁾ Order 2 for each hood

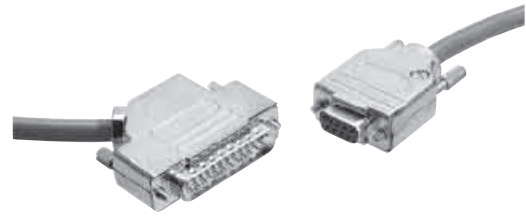

Full metal top and side entry hoods with knurled screws

Identification No. of contacts Part No. Drawing Dimensions in mm

Top entry hood

9	09 67 009 034 .
15	09 67 015 034 .
25	09 67 025 034 .
37	09 67 037 034 .

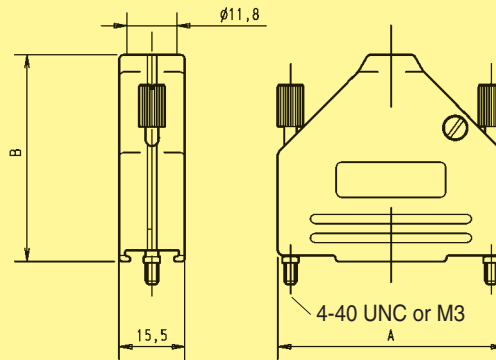

Poles	A	B
9	31.2	39.9
15	39.5	41.5
25	53.4	48.6
37	69.7	53.6

Please insert digit for screw option

- Knurled screw, thread 4-40 UNC ▶ 3
- Knurled screw, thread M3 ▶ 8

Grommet set halves

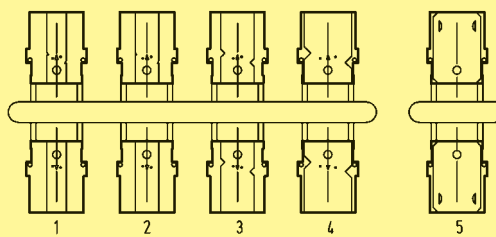

Grommet dimensions	
Number	Diameter
1	4.0
2	5.0
3	7.0
4	10.0
5	10.2

Side entry hood

9 ¹⁾	09 67 009 033 .
15	09 67 015 033 .
25	09 67 025 033 .
37	09 67 037 033 .

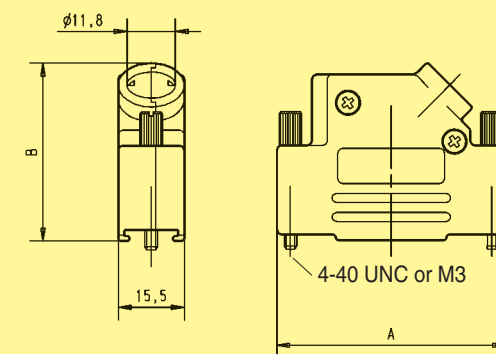

Poles	A	B
9	31.0	38.0
15	40.5	41.1
25	53.7	41.8
37	69.8	41.8

Please insert digit for screw option

- Knurled screw, thread 4-40 UNC ▶ 3
- Knurled screw, thread M3 ▶ 6

Grommet set halves

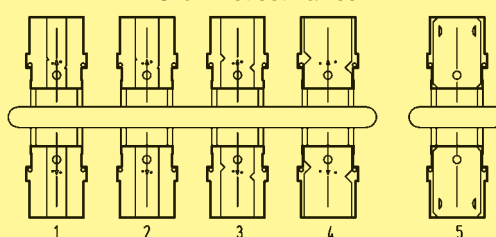

Grommet dimensions	
Number	Diameter
1	4.0
2	5.0
3	7.0
4	10.0
5	10.2

¹⁾ 9 pole hood provided with only one screw on the opposite side of the cable entry.

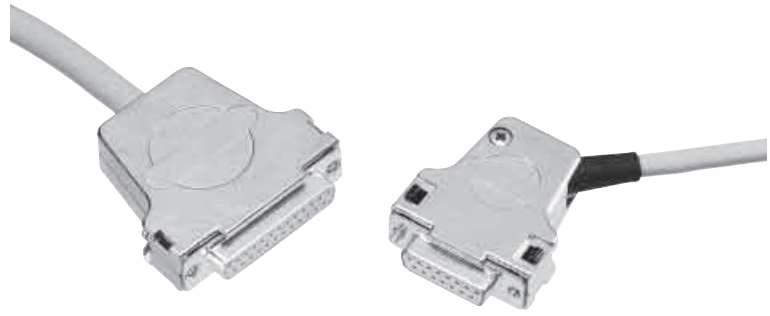

Full metal top and side entry hoods with short screws

Identification No. of contacts Part No. Drawing Dimensions in mm

Top entry hood

9	09 67 009 034
15	09 67 015 034
25	09 67 025 034
37	09 67 037 034
50	09 67 050 034

Please insert digit for screw option

- Locking screw, thread 4-40 UNC ▶ 4
- Locking screw, thread M3 ▶ 9

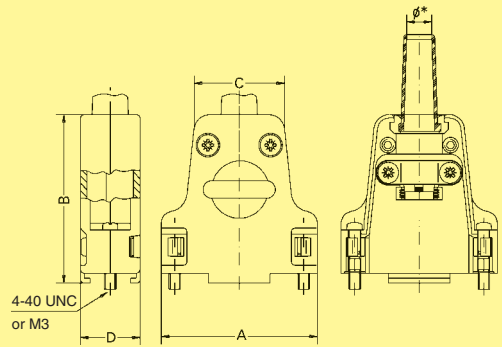

Poles	A	B	C	D	Ø F1		Ø F2	Ø F3
					Min.	Max.		
9	31.8	42.4	20.8	15.4	3.0	9.5	6.5	—
15	40.3	43.5	23.3	15.4	3.0	8.5	6.5	12.5
25	54.0	47.7	31.7	15.4	3.0	8.5	8.0	12.5
37	70.2	50.4	48.2	15.4	3.0	12.0	9.0	15.0
50	67.8	50.5	45.8	18.2	3.0	12.0	9.7	15.0

* Cable diameter without rubber bushing = Ø F1
 Cable diameter with rubber bushing = Ø F2
 Cable diameter without rubber bushing and without cable reduction plate = Ø F3

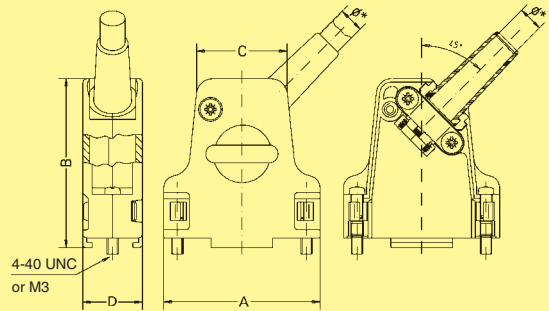

Side entry hood

9	09 67 009 033
15	09 67 015 033
25	09 67 025 033
37	09 67 037 033
50	09 67 050 033

Please insert digit for screw option

- Locking screw, thread 4-40 UNC ▶ 4
- Locking screw, thread M3 ▶ 5

Locking hook

09 67 002 9031

Latch lock bolt

Front mount

thread 4-40 UNC
thread M3

09 67 002 9041
09 67 002 9042

Rear mount

thread 4-40 UNC
thread M3

09 67 002 9032
09 67 002 9040

Cable to cable

thread 4-40 UNC
thread M3

09 67 002 9044
09 67 002 9045

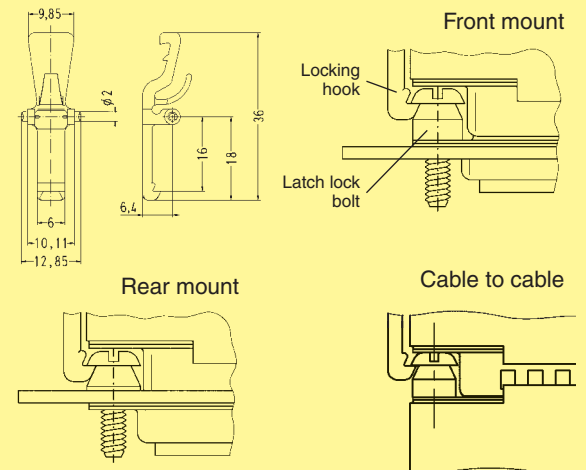

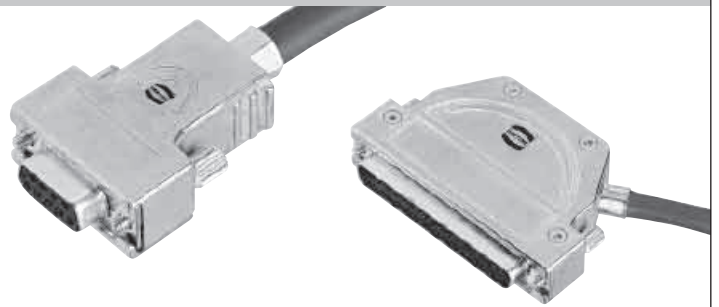

Full metal top and side entry hoods with different screw options

Identification No. of contacts Part No. Drawing Dimensions in mm

40° side entry hood

9	61 03 001 . 013
15	61 03 001 . 014
25	61 03 001 . 015

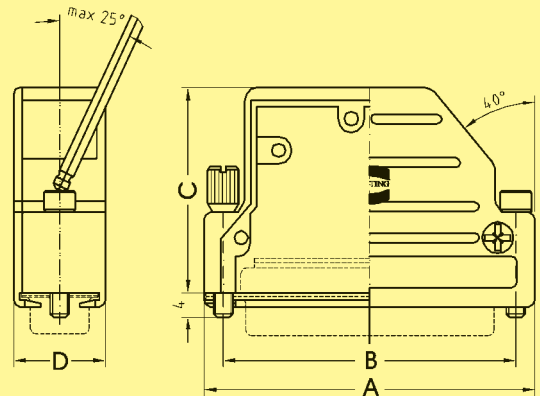

No. of contacts	A	B	C	D
9	31.0	25.0	35.0	15.0
15	39.3	33.3	35.0	15.0
25	53.0	47.0	35.0	15.0

Top/side entry hood

9	61 03 001 . 010
15	61 03 001 . 016
25	61 03 001 . 017 ¹⁾
37	61 03 001 . 018 ¹⁾
50	61 03 001 . 019 ¹⁾

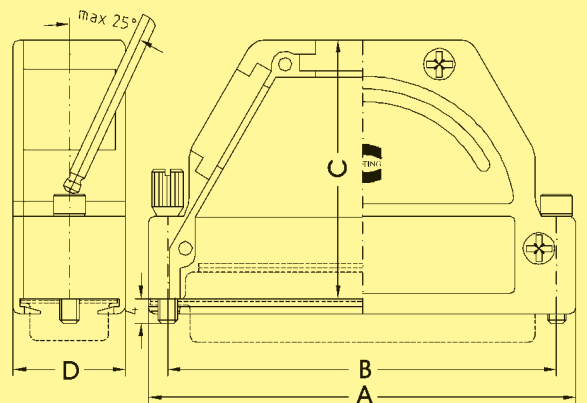

Please insert digit for screw option

- Knurled screw, thread 4-40 UNC ▶ 0
- Hexagonal screw, thread M3 with captive washer ▶ 1
- Hexagonal screw, thread 4-40 UNC with captive washer ▶ 2
- Knurled screw, thread M3 ▶ 3

No. of contacts	No. of cable entries	A	B	C	D
9	1 (top)	31.0	25.0	38.0	15.0
15	1 (top)	39.5	33.3	35.0	15.0
25	3	53.0	47.0	43.0	15.0
37	3	69.5	63.5	43.0	15.0
50	3	67.2	61.6	43.0	17.8

¹⁾ Part No. contains two blanking pieces

Connector hoods for spring or slide locking

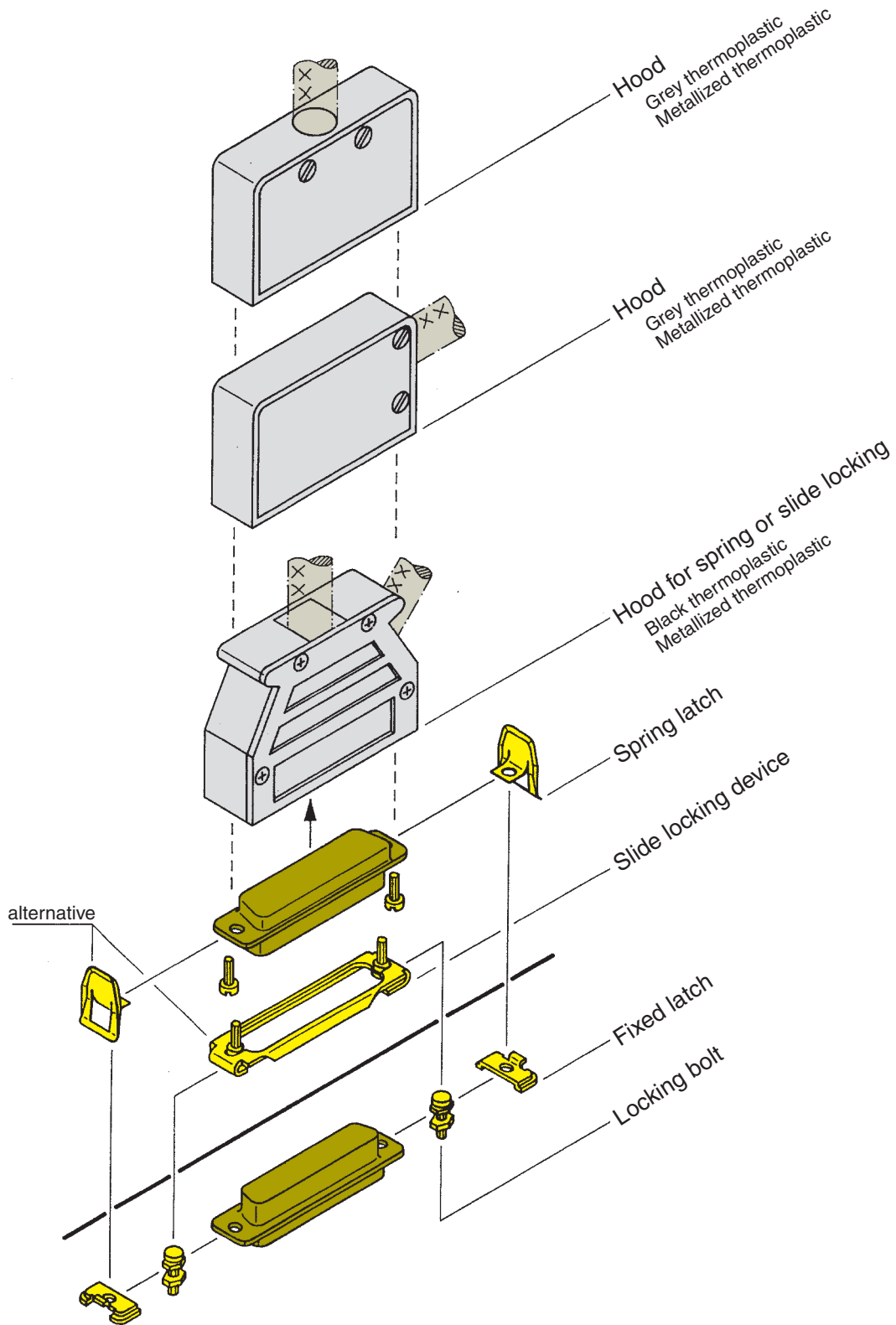

D-Sub - H



Thermoplastic top and side entry hoods for spring or slide locking

Identification No. of contacts Part No. Drawing Dimensions in mm

Top entry hood

No. of contacts	Thermoplastic grey	Thermoplastic metallized
9	09 67 009 0411	09 67 009 0413
15	09 67 015 0411	09 67 015 0413
25	09 67 025 0411	09 67 025 0413
37	09 67 037 0411	09 67 037 0413
50	09 67 050 0411	09 67 050 0413

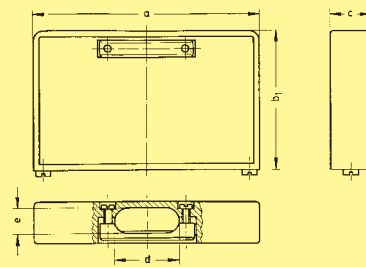

9-37 way for packaging density of 3 TE (15.24 mm)

	a	b ₁	b ₂	c	d	e	
						min.	max.
9	31.0	23	28	12.8	10	5.75	9.0
15	39.4	28	28	12.8	10	5.75	9.0
25	53.3	34	34	12.8	14	5.75	9.0
37	69.7	43	43	12.8	20	5.75	9.0
50	67.1	41	41	15.8	20	5.75	11.6

Side entry hood

No. of contacts	Thermoplastic grey	Thermoplastic metallized
9	09 67 009 0511	09 67 009 0513
15	09 67 015 0511	09 67 015 0513
25	09 67 025 0511	09 67 025 0513
37	09 67 037 0511	09 67 037 0513
50	09 67 050 0511	09 67 050 0513

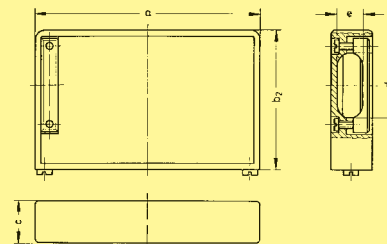

9-37 way for packaging density of 3 TE (15.24 mm)

Top and side entry hood¹⁾

No. of contacts	Thermoplastic black	Thermoplastic metallized
9	09 67 009 0452	09 67 009 0453
15	09 67 015 0452	09 67 015 0453
25	09 67 025 0452	09 67 025 0453
37	09 67 037 0452	09 67 037 0453
50	09 67 050 0452	09 67 050 0453

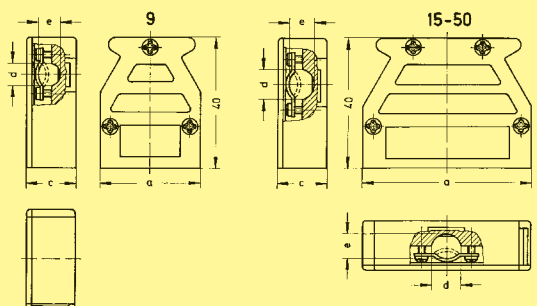

	a	c	d	e	
				min.	max.
9	31.0	15.4	7	1.7	7.5
15	39.4	15.4	7	1.7	8.0
25	53.2	15.4	9	1.5	8.0
37	69.5	15.4	9	1.5	8.0
50	67.0	17.9	9	1.5	8.0

¹⁾ 9 poles is only side entry
Accessories see page 07.13

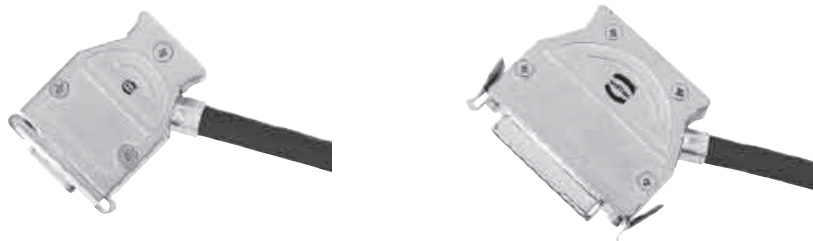

Full metal top and side entry hoods for spring or slide locking

Identification No. of contacts Part No. Drawing Dimensions in mm

Top/side entry hood with spring/slide locking

9 61 03 001 0022¹⁾
 15 61 03 001 0011²⁾
 25 61 03 001 0012²⁾
 37 61 03 001 0021²⁾
 50 61 03 001 0020²⁾

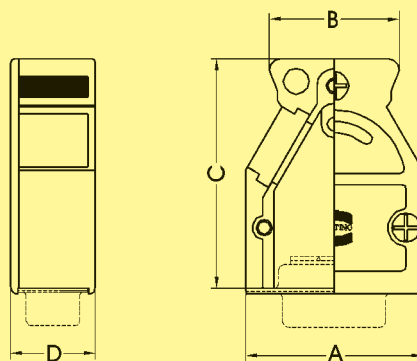

No. of contacts	No. of cable entries	A	B	C	D
9	2	31.0	22.6	40.0	14.8
15	3	39.0	30.6	40.0	14.8
25	3	53.0	42.6	40.0	14.8
37	3	69.5	59.2	40.0	14.8
50	3	67.0	55.0	40.0	17.6

D-Sub - H

¹⁾ Part No. contains one blanking piece
²⁾ Part No. contains two blanking pieces

Accessories for spring or slide locking hoods

Identification	No. of contacts	Part No.	Drawing	Dimensions in mm																														
Spring latch	9-50	corrosion resistant steel 09 67 000 9907 ¹⁾																																
Fixed latch	9-37 50	corrosion resistant steel 09 67 001 9971 ¹⁾ 09 67 001 9972 ¹⁾																																
Slide locking device	9 15 25 37 50	corrosion resistant steel 09 67 000 9914 09 67 000 9915 09 67 000 9916 09 67 000 9917 09 67 000 9918	 <table border="1"> <thead> <tr> <th></th> <th>a</th> <th>b</th> <th>c</th> <th>d</th> </tr> </thead> <tbody> <tr> <td>9</td> <td>35.6</td> <td>25.0</td> <td>12.0</td> <td>10.0</td> </tr> <tr> <td>15</td> <td>44.0</td> <td>33.3</td> <td>12.0</td> <td>10.0</td> </tr> <tr> <td>25</td> <td>57.8</td> <td>47.0</td> <td>12.0</td> <td>10.0</td> </tr> <tr> <td>37</td> <td>74.3</td> <td>63.5</td> <td>12.0</td> <td>10.0</td> </tr> <tr> <td>50</td> <td>72.0</td> <td>61.1</td> <td>14.8</td> <td>13.5</td> </tr> </tbody> </table>		a	b	c	d	9	35.6	25.0	12.0	10.0	15	44.0	33.3	12.0	10.0	25	57.8	47.0	12.0	10.0	37	74.3	63.5	12.0	10.0	50	72.0	61.1	14.8	13.5	
	a	b	c	d																														
9	35.6	25.0	12.0	10.0																														
15	44.0	33.3	12.0	10.0																														
25	57.8	47.0	12.0	10.0																														
37	74.3	63.5	12.0	10.0																														
50	72.0	61.1	14.8	13.5																														
Locking bolt	9-50	tinned 09 67 001 9973 ¹⁾																																

D-Sub - H

¹⁾ Order 2 for each connector

Accessories for full metal hoods

Identification	Part No.		Drawing	Dimensions in mm																																																										
Crimp flange	Hoods for 9-37 pole D-Sub	Hoods for 50 pole D-Sub	<table border="1"> <thead> <tr> <th>D1</th> <th>D2</th> </tr> </thead> <tbody> <tr><td>3.0</td><td>4.0</td></tr> <tr><td>3.5</td><td>4.5</td></tr> <tr><td>4.0</td><td>5.0</td></tr> <tr><td>4.5</td><td>5.5</td></tr> <tr><td>5.0</td><td>6.0</td></tr> <tr><td>5.5</td><td>6.5</td></tr> <tr><td>6.0</td><td>7.0</td></tr> <tr><td>6.5</td><td>7.5</td></tr> <tr><td>7.0</td><td>8.0</td></tr> <tr><td>7.5</td><td>8.5</td></tr> <tr><td>8.0</td><td>9.0</td></tr> <tr><td>8.5</td><td>9.5</td></tr> <tr><td>9.0</td><td>10.0</td></tr> </tbody> </table>	D1	D2	3.0	4.0	3.5	4.5	4.0	5.0	4.5	5.5	5.0	6.0	5.5	6.5	6.0	7.0	6.5	7.5	7.0	8.0	7.5	8.5	8.0	9.0	8.5	9.5	9.0	10.0	<table border="1"> <thead> <tr> <th>D1</th> <th>D2</th> </tr> </thead> <tbody> <tr><td>3.0</td><td>4.0</td></tr> <tr><td>3.5</td><td>4.5</td></tr> <tr><td>4.0</td><td>5.0</td></tr> <tr><td>4.5</td><td>5.5</td></tr> <tr><td>5.0</td><td>6.0</td></tr> <tr><td>5.5</td><td>6.5</td></tr> <tr><td>6.0</td><td>7.0</td></tr> <tr><td>6.5</td><td>7.5</td></tr> <tr><td>7.0</td><td>8.0</td></tr> <tr><td>7.5</td><td>8.5</td></tr> <tr><td>8.0</td><td>9.0</td></tr> <tr><td>8.5</td><td>9.5</td></tr> <tr><td>9.0</td><td>10.0</td></tr> </tbody> </table>	D1	D2	3.0	4.0	3.5	4.5	4.0	5.0	4.5	5.5	5.0	6.0	5.5	6.5	6.0	7.0	6.5	7.5	7.0	8.0	7.5	8.5	8.0	9.0	8.5	9.5	9.0	10.0		
	D1	D2																																																												
	3.0	4.0																																																												
	3.5	4.5																																																												
	4.0	5.0																																																												
	4.5	5.5																																																												
	5.0	6.0																																																												
	5.5	6.5																																																												
	6.0	7.0																																																												
	6.5	7.5																																																												
	7.0	8.0																																																												
	7.5	8.5																																																												
	8.0	9.0																																																												
	8.5	9.5																																																												
9.0	10.0																																																													
D1	D2																																																													
3.0	4.0																																																													
3.5	4.5																																																													
4.0	5.0																																																													
4.5	5.5																																																													
5.0	6.0																																																													
5.5	6.5																																																													
6.0	7.0																																																													
6.5	7.5																																																													
7.0	8.0																																																													
7.5	8.5																																																													
8.0	9.0																																																													
8.5	9.5																																																													
9.0	10.0																																																													
Crimp ferrule	<table border="1"> <tbody> <tr><td>61 03 000 0045</td></tr> <tr><td>61 03 000 0046</td></tr> <tr><td>61 03 000 0047</td></tr> <tr><td>61 03 000 0048</td></tr> <tr><td>61 03 000 0049</td></tr> <tr><td>61 03 000 0050</td></tr> <tr><td>61 03 000 0051</td></tr> <tr><td>61 03 000 0052</td></tr> <tr><td>61 03 000 0053</td></tr> <tr><td>61 03 000 0054</td></tr> <tr><td>61 03 000 0055</td></tr> <tr><td>61 03 000 0056</td></tr> <tr><td>61 03 000 0057</td></tr> <tr><td>61 03 000 0058</td></tr> <tr><td>61 03 000 0142</td></tr> <tr><td>61 03 000 0059</td></tr> <tr><td>61 03 000 0127</td></tr> <tr><td>61 03 000 0060</td></tr> <tr><td>61 03 000 0061</td></tr> </tbody> </table>		61 03 000 0045	61 03 000 0046	61 03 000 0047	61 03 000 0048	61 03 000 0049	61 03 000 0050	61 03 000 0051	61 03 000 0052	61 03 000 0053	61 03 000 0054	61 03 000 0055	61 03 000 0056	61 03 000 0057	61 03 000 0058	61 03 000 0142	61 03 000 0059	61 03 000 0127	61 03 000 0060	61 03 000 0061	<table border="1"> <thead> <tr> <th>D3</th> <th>D4</th> </tr> </thead> <tbody> <tr><td>5.0</td><td>6.0</td></tr> <tr><td>5.5</td><td>6.5</td></tr> <tr><td>6.0</td><td>7.0</td></tr> <tr><td>6.5</td><td>7.5</td></tr> <tr><td>7.0</td><td>8.0</td></tr> <tr><td>7.5</td><td>8.5</td></tr> <tr><td>8.0</td><td>9.0</td></tr> <tr><td>8.5</td><td>9.5</td></tr> <tr><td>9.0</td><td>10.0</td></tr> <tr><td>9.5</td><td>10.5</td></tr> <tr><td>10.0</td><td>11.0</td></tr> <tr><td>10.5</td><td>11.5</td></tr> <tr><td>11.0</td><td>12.0</td></tr> <tr><td>11.5</td><td>12.5</td></tr> <tr><td>12.0</td><td>13.0</td></tr> <tr><td>12.5</td><td>13.5</td></tr> <tr><td>13.0</td><td>14.0</td></tr> <tr><td>13.7</td><td>15.0</td></tr> <tr><td>14.0</td><td>15.0</td></tr> </tbody> </table>	D3	D4	5.0	6.0	5.5	6.5	6.0	7.0	6.5	7.5	7.0	8.0	7.5	8.5	8.0	9.0	8.5	9.5	9.0	10.0	9.5	10.5	10.0	11.0	10.5	11.5	11.0	12.0	11.5	12.5	12.0	13.0	12.5	13.5	13.0	14.0	13.7	15.0	14.0	15.0
	61 03 000 0045																																																													
	61 03 000 0046																																																													
	61 03 000 0047																																																													
	61 03 000 0048																																																													
	61 03 000 0049																																																													
	61 03 000 0050																																																													
	61 03 000 0051																																																													
	61 03 000 0052																																																													
	61 03 000 0053																																																													
	61 03 000 0054																																																													
	61 03 000 0055																																																													
	61 03 000 0056																																																													
	61 03 000 0057																																																													
	61 03 000 0058																																																													
	61 03 000 0142																																																													
	61 03 000 0059																																																													
	61 03 000 0127																																																													
	61 03 000 0060																																																													
	61 03 000 0061																																																													
	D3	D4																																																												
5.0	6.0																																																													
5.5	6.5																																																													
6.0	7.0																																																													
6.5	7.5																																																													
7.0	8.0																																																													
7.5	8.5																																																													
8.0	9.0																																																													
8.5	9.5																																																													
9.0	10.0																																																													
9.5	10.5																																																													
10.0	11.0																																																													
10.5	11.5																																																													
11.0	12.0																																																													
11.5	12.5																																																													
12.0	13.0																																																													
12.5	13.5																																																													
13.0	14.0																																																													
13.7	15.0																																																													
14.0	15.0																																																													
Cable clamp	cable-Ø appr. 5- 7 mm	61 03 000 0141																																																												
	cable-Ø appr. 7-10 mm	61 03 000 0044																																																												
	cable-Ø appr. 10-12 mm	61 03 000 0143																																																												
	cable-Ø appr. 11-14 mm	61 03 000 0145																																																												
Blanking piece for hoods	61 03 000 0042	61 03 000 0041																																																												
Hexagonal screw	thread 4-40 UNC x 17.5-8.8 with captive washer	09 67 002 9020																																																												
	thread M3 x 17.5-8.8 with captive washer	09 67 002 9019																																																												
Knurled screw	thread 4-40 UNC	09 67 002 9018																																																												
	thread M3	09 67 002 9017																																																												

Crimp flange termination instruction

1. Strip the cable sheath to the correct length (approx. 35 to 40 mm, depending on interface type).
2. Place the crimp ferrule over the cable sheath. Bend the outer screen backwards over the cable sheath. Cut screen approx. 2 mm from the end of the cable sheath.
3. Place the crimp flange over the wires covered by the remaining foil shield. Push and twist the crimp flange under the outer screen and cable sheath until the end of the cable sheath touches the crimp flange. HARTING has developed a special tool for optimised installation of the shielding over the crimp flange, part number 61 03 600 0017.
4. Move the crimp ferrule back onto the crimp flange and crimp the two parts together with the special service crimp tool part number 61 03 600 0020. For an optimised crimp process the tool should be positioned as close as possible to the crimp flange shoulder.
5. Cut off the internal screen foil and push the crimp flange inside the metal hood.

HARTING offers to test and define the best crimp flange and ferrule combination for customer specific cables.

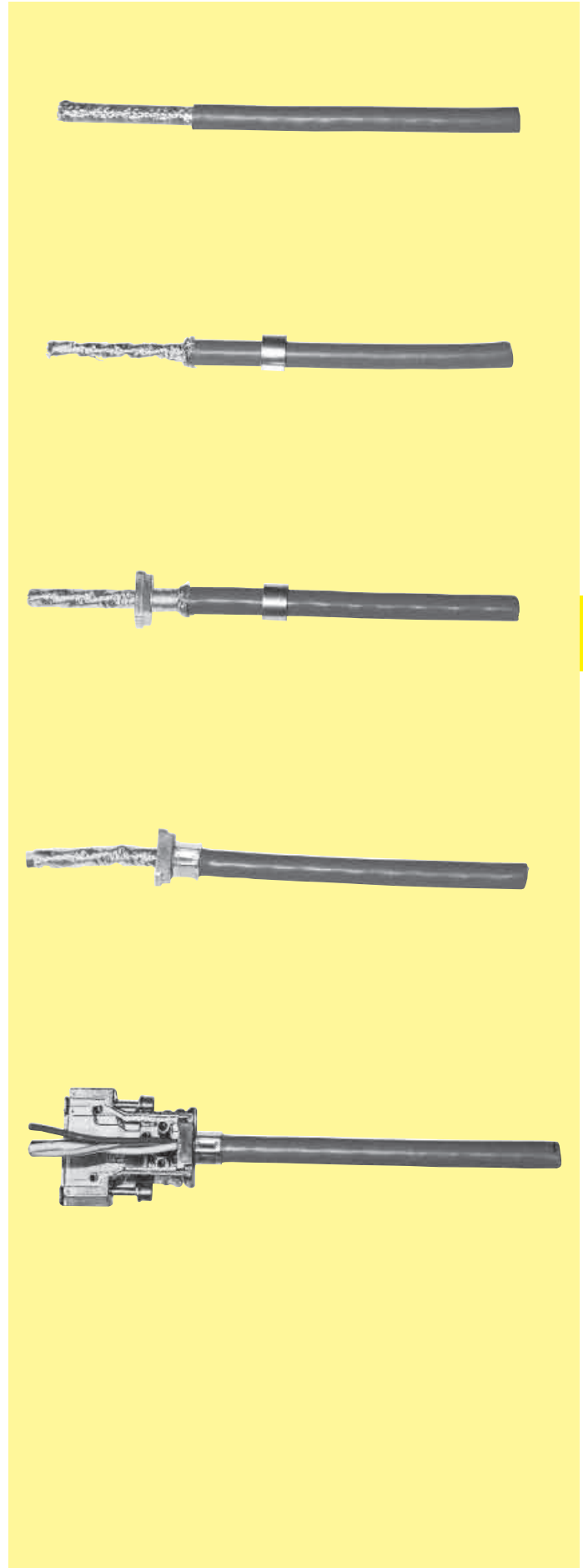



D-Sub - H