

<b>harbus<sup>®</sup> HM</b> Power – general information . . . . .	<b>03.02</b>
Technical characteristics . . . . .	<b>03.03</b>
Angled male connectors with press-in termination . . . . .	<b>03.04</b>
Angled male connectors with solder (SMC) termination . . . . .	<b>03.05</b>
Straight female connectors with press-in termination . . . . .	<b>03.06</b>

The **harbus<sup>®</sup> HM** HM Power connector is designed according to the OBSAI Specification V 1.1. It is well-suited to be used in conjunction with 2 mm **harbus<sup>®</sup> HM** connectors. The durability is according to IEC 61076-4-101 (250 mating cycles).

The straight female connector for the backplane is fitted with press-in contacts, the right angled male connector for daughter cards can be supplied with either press-in or PIHIR (Pin In Hole Intrusive Reflow) termination.

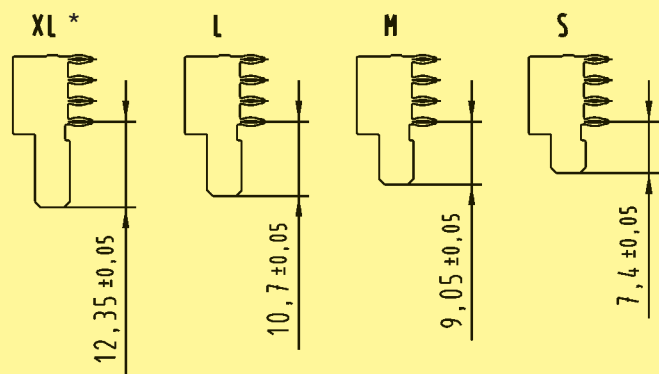

The compact, high temperature moulding can be loaded with up to four high current contacts. Four different contact lengths are available from 7.4 mm to 12.35 mm. This makes sequenced and non sequenced loadings possible (e.g. with GND and ENA). Any other contact assignments, also partially loaded, are available on request.

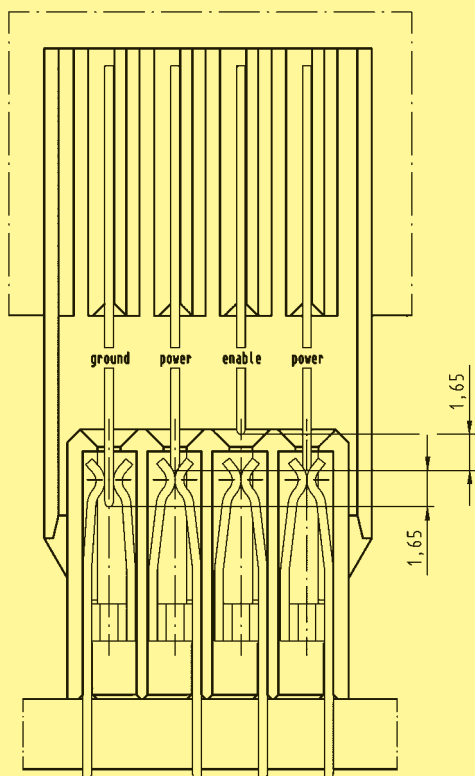

Loaded with four power contacts, each contact can carry up to 20 A @ 70 °C / 80 % derating.

**With a configuration of two power contacts, GND and ENA, the current carrying capacity is even up to 23 A @ 70 °C / 80 % derating per contact.**

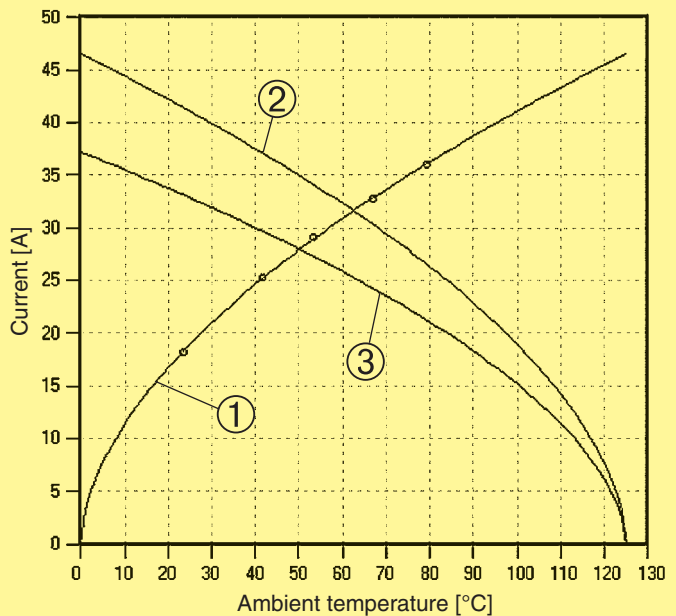

- ① Temperature raise
- ② Derating
- ③ Derating curve at  $I_{max} \times 0.8$  (DIN EN 60512-5-2)

The distance between adjacent contacts is 3 mm, which enables wider pcb traces, larger solder paste areas and an improved heat dissipation. For the female backplane connector no special tooling is necessary due to the flatrock design. For the male connector HARTING offers a special press-in tool (see chapter 15).

HARTING's **harbus<sup>®</sup> HM** Signal and Power connectors meet OBSAI (Open Base Station Architecture Initiative) specifications and provide a reliable and cost effective solution for connecting plug-in units to the backplane. The connector solutions available from the HARTING technology group will offer full compatibility and intermateability with base station modules.

**Benefits:**

- Small form factor
- High current rating up to 23 A per contact (OBSAI configuration)
- 3 level staggering (or even 4)
- Flatrock design
- Matched with **harbus<sup>®</sup> HM** 2 mm connectors

\* Type XL on request

Design according	: OBSAI System Spezifikation V 1.1
Number of contacts	: up to 4
Contact spacing	: 3.00 mm
Clearance and creepage distances between contacts	: > 2.3 mm
Working current	: 23 A max. (OBSAI configuration) 20 A max. (fully loaded with power contacts)
Test voltage $U_{r.m.s.}$	: AC 1500 V min.
Contact resistance	: < 1 m $\Omega$
Insulation resistance:	: > 10 G $\Omega$
Temperature range	: - 55 °C ... + 125 °C
during reflow soldering	220 °C for 2 minutes, 260 °C max. short-term
Durability as per IEC 61 076-4-101	: <i>Performance level 2 = 250 mating cycles in total.</i>  First 125 mating cycles, then 4 days gas test using 0.5 ppm SO <sub>2</sub> and 0.1 ppm H <sub>2</sub> S (at 25 + 2 °C and 75 + 3 % humidity). Measurement of contact resistance.  The remaining 125 mating cycles are subject to measurement of contact resistance and visual inspection. No abrasion of the contact finish through to the base material. No functional impairment.
Termination technique	
Male connectors	: Press-in or solder termination, suitable for (lead-free) pin-in-hole reflow soldering
Female connectors	: Press-in termination
Mating force	: max. 4 N / contact
Withdrawal force	: min. 0.5 N / contact
Materials	
Mouldings	: Thermoplastic resin, glass-fibre filled, UL 94-V0
Contacts	: Copper alloy
Contact surface	: Selectively gold plated (contact zone)
Contact styles	: Standard, leading, lagging
Packaging	
Tube	: Male and female connectors
Tape & Reel	: On request for male solder connectors

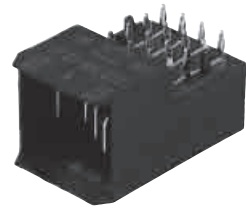

## Male connectors angled, with press-in termination

Identification	Number of contacts	Contact length [mm] termination side	Part number	Contact loading
Connector with same sized contacts	4	2.8	17 61 004 2102	 Position — 4 3 2 1
Connector with same sized contacts	4	2.8	17 61 004 2103	 Position — 4 3 2 1
Connector with leading/lagging contacts OBSAI configuration	4	2.8	17 61 004 2101	 Position — 4 3 2 1
Connector with leading contact	4	2.8	17 61 004 2104	 Position — 4 3 2 1

### Contact dimensions [mm]

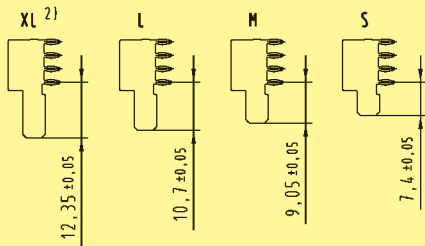

### Connector dimensions [mm]

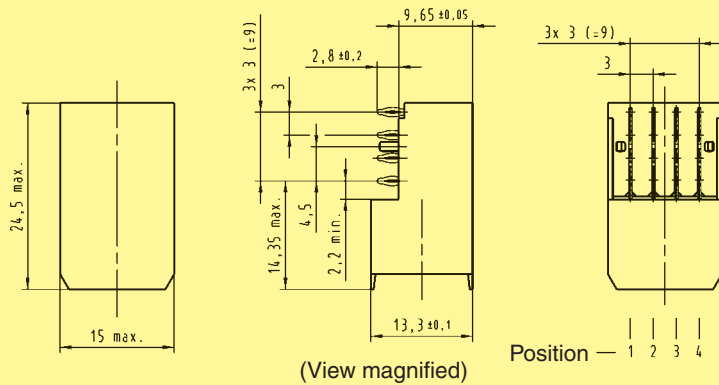

### Board drillings

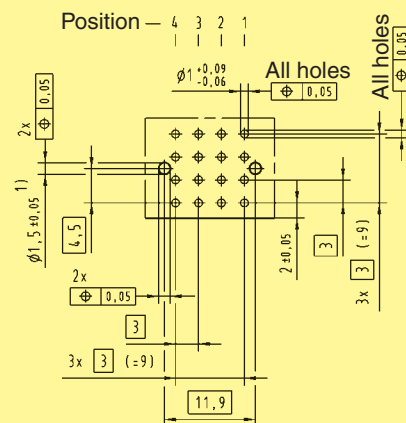

1) Non-metallized drillings  
2) Type XL on request  
Tooling see chapter 15

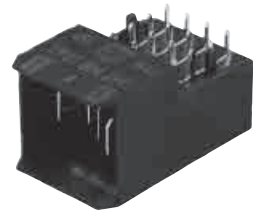

Male connectors angled, with solder (SMC) termination

Identification	Number of contacts	Contact length [mm] termination side	Part number	Contact loading
Connector with same sized contacts	4	2.5	17 61 004 2802	 Position — 4 3 2 1
Connector with leading/lagging contacts OBSAI configuration	4	2.5	17 61 004 2801	 Position — 4 3 2 1

harbus<sup>®</sup> HM Power

Contact dimensions [mm]

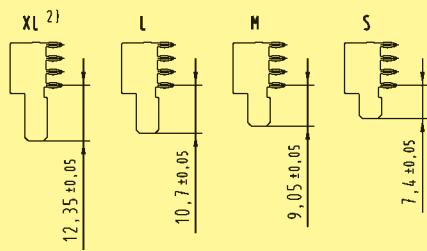

Connector dimensions [mm]

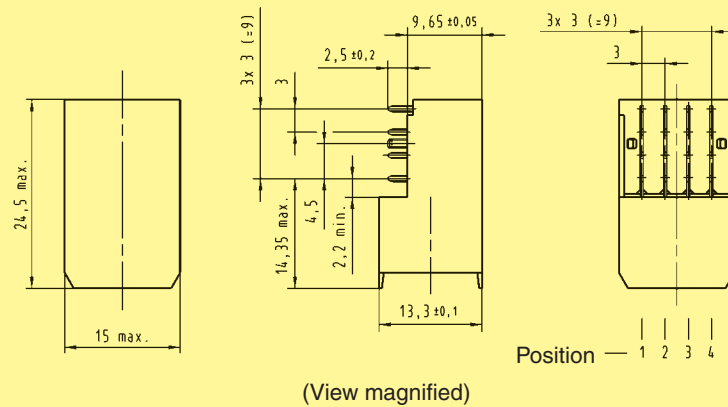

Board drillings

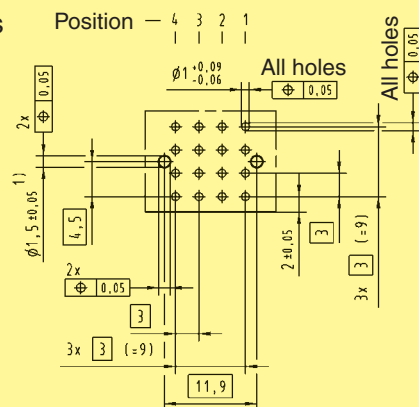

1) Non-metallized drillings  
2) Type XL on request



Female connector straight, with press-in termination

Identification	Number of contacts	Contact length [mm] termination side	Part number
Connector	4	3.7	17 66 004 2201

Connector dimensions [mm]

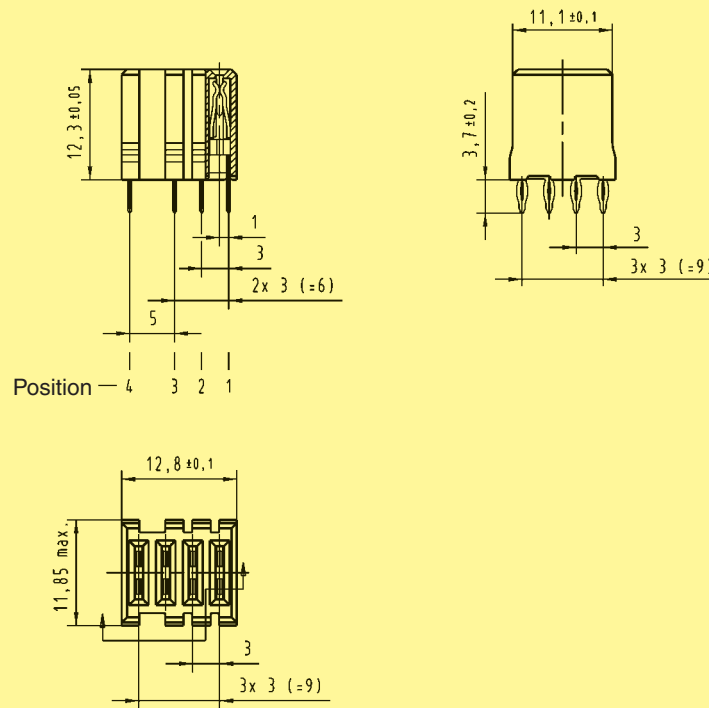

Board drillings

